

Uniclass L68111:P91	Epic F811
CI/SfB Ry	(K2)

June 2022

# Kemwell Fire Rated Partitions and Walls

A guide to fire rated partitions and walls using Fire**Kem** FP-900 High Performance  
**A1 non-combustible** high performance Calcium Silicate Board



SAVING LIVES | PROTECTING BUILDINGS & CONTENTS | MAINTAINING VITAL SERVICES

## PASSIVE FIRE PROTECTION

Specialists for the construction, infrastructure, transport, energy, industrial and commercial sectors.



SERVER SYSTEM 5000

SERVER SYSTEM 5000

SERVER SYSTEM 5000

# Contents

Product Overview	4
General Fire Partition Information	6
Internal Partitions	7
Timber Frame	
Steel Frame	
Shaft Wall Partitions	13
Solid Partitions	15
Fire Protection of Wind Posts	16
Technical Properties	19



## A High Performance non-combustible Fire Protection Board

Kemwell FireKem FP-900® is an easy to install, clean and lightweight, non-combustible calcium silicate fire protection building board. It has multi-purpose applications and is commonly used for commercial and industrial building projects.

As a versatile A1 non-combustible board, it is perfect for internal partitions, external walls, roofs, floors and ceilings, and is particularly suited for dry wall construction applications.

The inherent alkalinity of the board makes it anti-bacterial, meaning it is suitable for use in conditions where hygiene is of concern, such as hospitals or food-preparation areas.

It provides superior fire resistance performance and excellent dimensional stability under heat and severe moisture environments making it an ideal choice for a variety of projects.

You can specify Kemwell FireKem FP-900® with confidence.

### COMPOSITION

FireKem FP-900® is an environmentally-friendly 100% asbestos-free autoclaved lightweight calcium silicate, fire protection building board, manufactured from a homogeneous mixture of cement, organic cellulose fibres and selected mineral binder.

The autoclaving process promotes the crystallisation of the calcium silicate, which in turn contributes to the exceptional dimensional stability of the board.

It has a smooth sanded front face and an unsanded back face.

It is not classified as a dangerous substance and can be placed in an on-site skip with other general building waste.

### SUPPORT

The Kemwell project team provides expert support services throughout all stages of any construction project, including:

- Technical advice
- Supply of data sheets and certification
- Product selection and application consultation
- Site-visits
- Installation advice

Please contact us to discuss your project or requirements further.

T: +44 (0) 333 344 0699 (UK)  
T: +353 (0) 1 565 3756 (Ireland)  
E: [info@kemwell-pfp.com](mailto:info@kemwell-pfp.com)



## APPLICATIONS

- Ceilings
- Cavity barriers
- Roofs and floors
- Partitions and external walls
- Tunnel linings
- Wind posts
- Electrical and mechanical services enclosures
- Smoke barriers
- Fire doors

## SECTORS

- Industrial
- Commercial buildings
- High-rise construction
- Health and leisure
- Schools and Educational
- Restaurants and hotels
- Residential properties
- Infrastructure



## FEATURES



### Fire Resistance

FireKem FP-900® has superior fire resistance performance and the boards are approved for up to 240 minutes fire resistance according to BS 476: Part 22: 1987 depending on application.



### Dimensional Stability

FireKem FP-900® has excellent dimensional stability under elevated temperatures and in severe moisture environments.



### Moisture Resistant

FireKem FP-900® will not deteriorate when used in damp or humid conditions and will not encourage mould growth. The boards are also rot proof.

Performance characteristics are not degraded by age or moisture. Untreated surfaces will absorb water, which can cause some loss of strength, but full strength is regained after drying.



### Chemical Stability

FireKem FP-900® is a chemically inert calcium silicate board, unaffected by contact with most chemicals and resistant to dilute acids and alkalis.



### Acoustic Performance

FireKem FP-900® provides good acoustic reduction performance of between 26-49dB. It also provides thermal conductivity (approximately) at 20°C of 0.17 W/mK.



### Easy Workability

No special equipment is required for cutting or drilling of FireKem FP-900® boards. It is recommended that cutting of the boards is carried out in well-ventilated situations, or the wearing of suitable dust masks to reduce the hazard of nuisance dust production, during the cutting or drilling process. Boards may be flat head nailed or pilot drilled, then screwed.



### Smooth Surface

FireKem FP-900® has a smooth surface but due to their high suction should be first sealed prior to applying paints, plasters, or wallpapers.



### Durability

FireKem FP-900® is a lightweight but strong building board. System performance is unaffected by the hazards and condition of its working environment it does not rot.



### Vermin Resistant

FireKem FP-900® boards remain unaffected by rodent, termite and insect attack.



## General Fire Partition Information

In modern buildings, both internal and external walls can be used to form compartments, acting as barriers to contain the spread of fire. These fire separating elements must satisfy the relevant basic fire criteria of Integrity (E) and Insulation (I) for the required fire resistance period, relative to the particular application and conditions within the building. Our partitions are designed to resist the spread of fire, heat, and the products of combustion for periods of time to suit the regulations and building conditions.

The FireKem FP-900® board systems are suitable for non-load bearing and load bearing installations in industrial, commercial, high-rise residential, and a variety of building types and constructions. As a single board system it leads to simpler construction, with associated productivity, and cost benefits.

### General Design Information

When considering the required integrity of walls/partitions under both Fire and Ambient conditions, the following should be taken into account.

### Non-Load Bearing Partitions

Consisting of timber or steel studwork, or of solid construction. The size of stud being determined by the partition height.

### Load Bearing Partitions

Load bearing capacities of partitions should be calculated in accordance with BS 476: Part 21: 1987 (BS EN 1365-1 to 6: 1999 - 2004), AS4600, and AS1170 with regard to partition height and decrease in the yield strength of steel at elevated temperatures.

### Deflection

Where relevant movement may occur between floors bounding any Fire Partition, allowance must be made in the form of a Deflection Head Track. Expansion of steel studwork under fire conditions must also be taken into account at the design stage.

### Service Penetrations

Movement of Service Penetrations must be taken in account in the partition design (movement being in normal service and fire conditions).

Fire stopping materials at the penetration location must be compatible with the partition to maintain the integrity of the partition.

### Movement Joint

Stress in the partition resulting from movement differentials between the primary building structures and the partition may be reduced by incorporating into the design various suitable movement/expansion joints.



## Timber Studs

### TECHNICAL DATA

60 minutes fire rating, integrity and insulation in accordance with BS 476: Part 22: 1987.

Maximum partition height:	4.0m
Nominal thickness of partition:	81mm
Estimated sound insulation:	Rw 41dB

- 1 Timber stud 63mm x 50mm at 610mm maximum centres.
- 2 Timber nogging at horizontal board joints.
- 3 Rock wool, minimum 60mm thick x 23kg/m<sup>3</sup>.
- 4 Rock wool or intumescent seal.
- 5 M6 steel anchor bolt at nominal 600mm centres.
- 6 M4 screws or round head nails at nominal 300mm centres.
- 7 FireKem FP-900® boards 9mm thick, both sides butt jointed.
- 8 Concrete wall or slab floor.

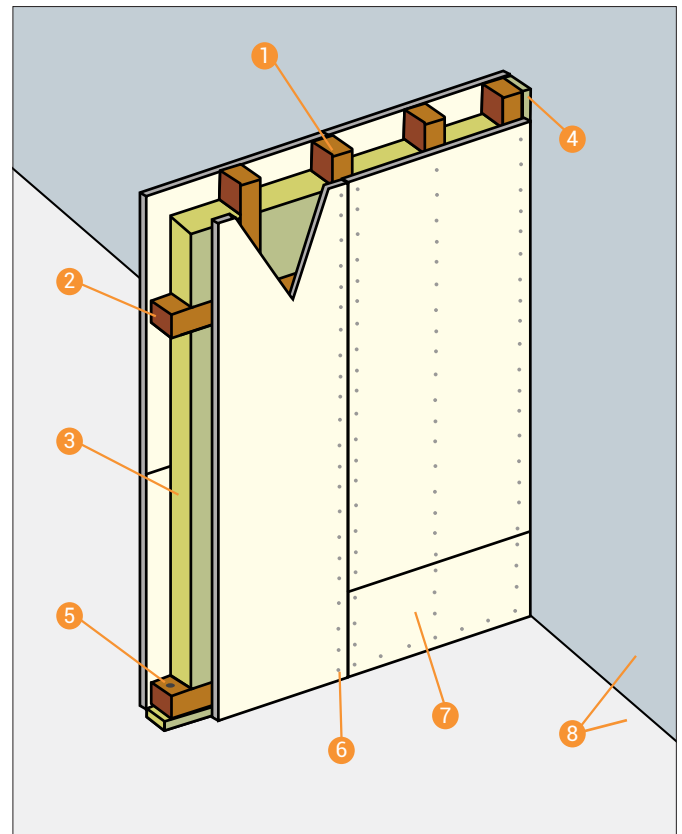

### TECHNICAL DATA

120 minutes fire rating, integrity and insulation in accordance with BS 476: Part 22: 1987.

Nominal thickness of partition:	119mm
Maximum partition height:	4.0m
Estimated sound insulation: Rw	47dB

- 1 Timber stud 89mm x 50mm at maximum 610mm centres.
- 2 Timber nogging at horizontal board joints.
- 3 Rock wool, minimum 80mm thick x 100kg/m<sup>3</sup> applied in 2 layers with all joints staggered.
- 4 Rock wool or intumescent seal.
- 5 M6 steel anchor bolt at nominal 600mm centres.
- 6 M4 screws or round head nails at nominal 300mm centres.
- 7 FireKem FP-900® boards 15mm thick, both sides butt jointed.
- 8 Concrete wall or slab floor.

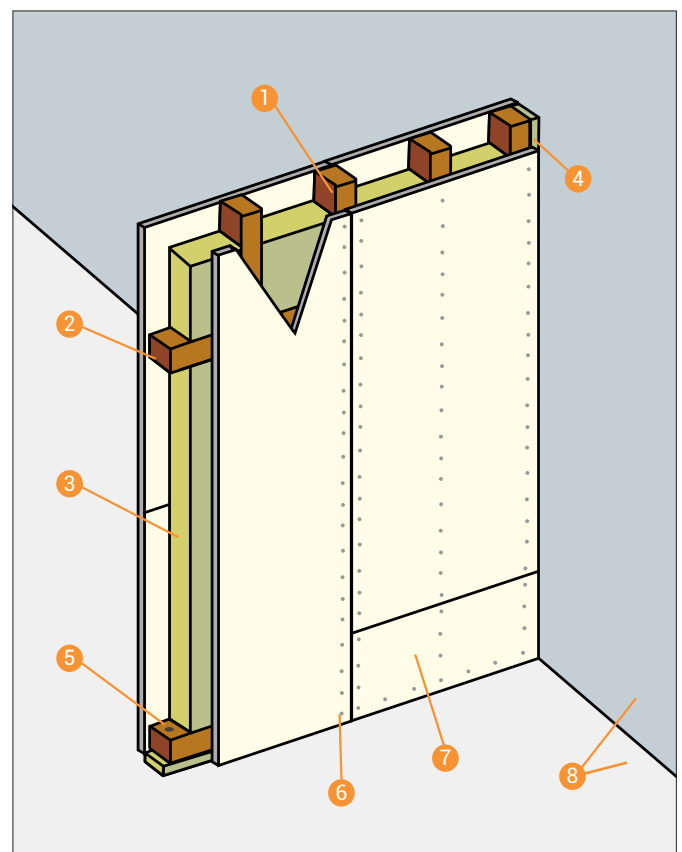

## Single Sided Steel Stud Partition

### TECHNICAL DATA

60 minutes fire rating, integrity only in accordance with BS EN 1364-1: 1999.

Nominal thickness of partition:	57mm
Maximum partition height:	6.0m
Estimated sound insulation:	Rw 29dB

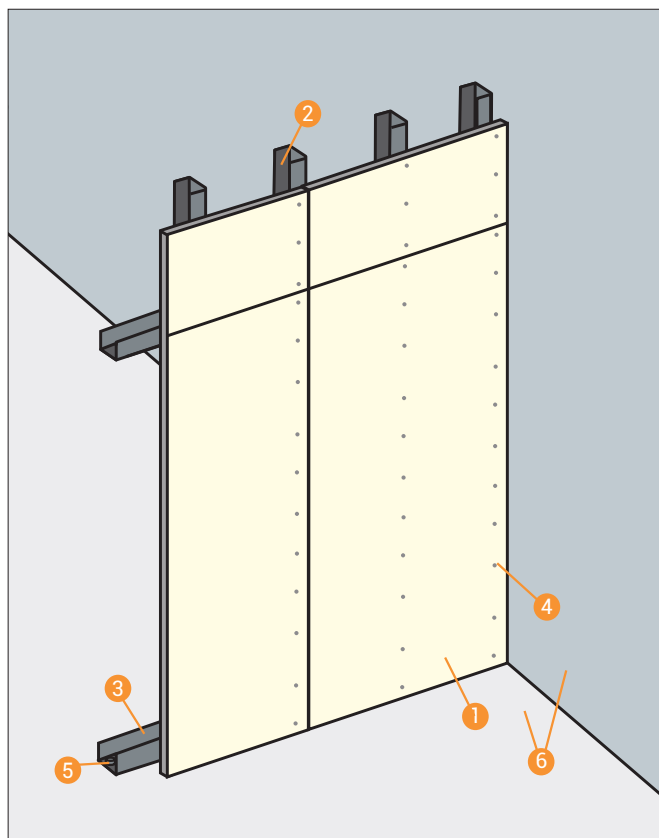

- 1 FireKem FP-900® board 9mm thick, butt jointed to fire risk side.
- 2 C - stud, 60mm x 32/34mm x 0.5mm, at maximum 600mm centres.
- 3 Ceiling and floor channel, minimum 62mm x 40mm x 0.5mm.
- 4 M4 self tapping screws at nominal 300mm centres.
- 5 M6 steel anchor bolt at nominal 500mm centres.
- 6 Concrete wall or slab floor.

### TECHNICAL DATA

240 minutes fire rating, integrity only in accordance with BS EN 1364-1: 1999.

Nominal thickness of partition:	66mm
Maximum partition height:	6.0m
Estimated sound insulation:	Rw 29dB

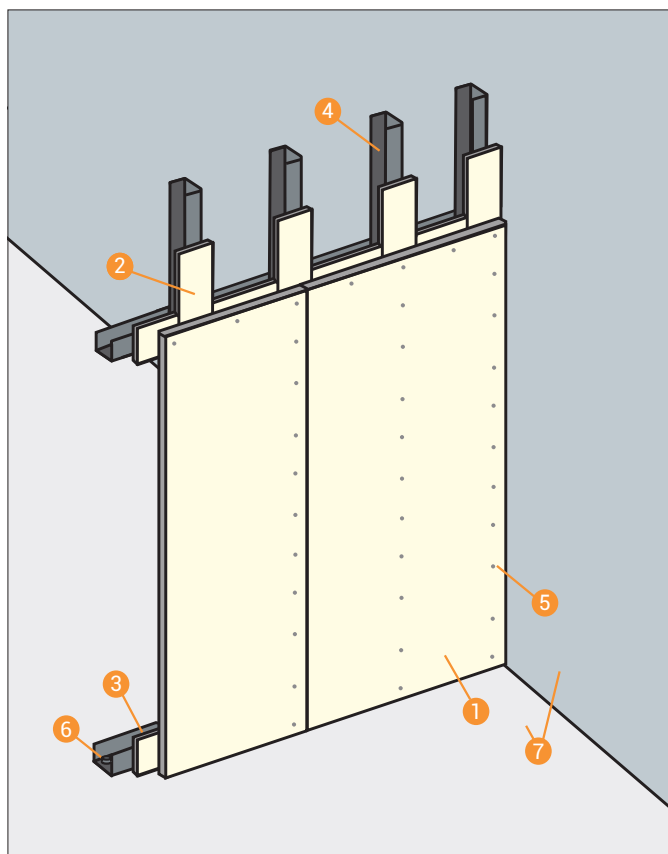

- 1 FireKem FP-900® boards 9mm thick, butt jointed to fire risk side.
- 2 100mm FireKem FP-900® coverstrips fixed to vertical and horizontal studs with M4 x 25mm self tapping screws at 600mm centres.
- 3 Ceiling and floor channel, minimum 76mm x 50mm x 0.5mm.
- 4 C - stud, 75mm x 40mm x 0.5mm, at maximum 600mm centres.
- 5 M4 self tapping screws at nominal 300mm centres.
- 6 M6 steel anchor bolt at nominal 500mm centres.
- 7 Concrete wall or slab floor.



# Kemwell FireKem FP-900® Internal Partitions - EI 60

## Steel Frame

### TECHNICAL DATA

60 minutes fire rating, integrity and insulation in accordance with BS 476: Part 22: 1987.

Nominal thickness of partition:	78mm
Maximum partition height:	6.0m
Estimated sound insulation:	Rw 29dB

- 1 FireKem FP-900® board 9mm thick, butt jointed.
- 2 FireKem FP-900® coverstrips 50mm wide fixed to both vertical and horizontal studs, board fixed with M4 x 25mm self tapping screws at 300mm centres.
- 3 Rock wool, minimum 60mm thick x 23kg/m<sup>3</sup>.
- 4 Rock wool or intumescent seal.
- 5 Steel stud 48mm x 32/34mm x 0.5mm, fixed at 600mm centres.
- 6 M6 steel anchor bolt at nominal 500mm centres.
- 7 Steel channel ceiling and floor.
- 8 Concrete wall or slab floor.

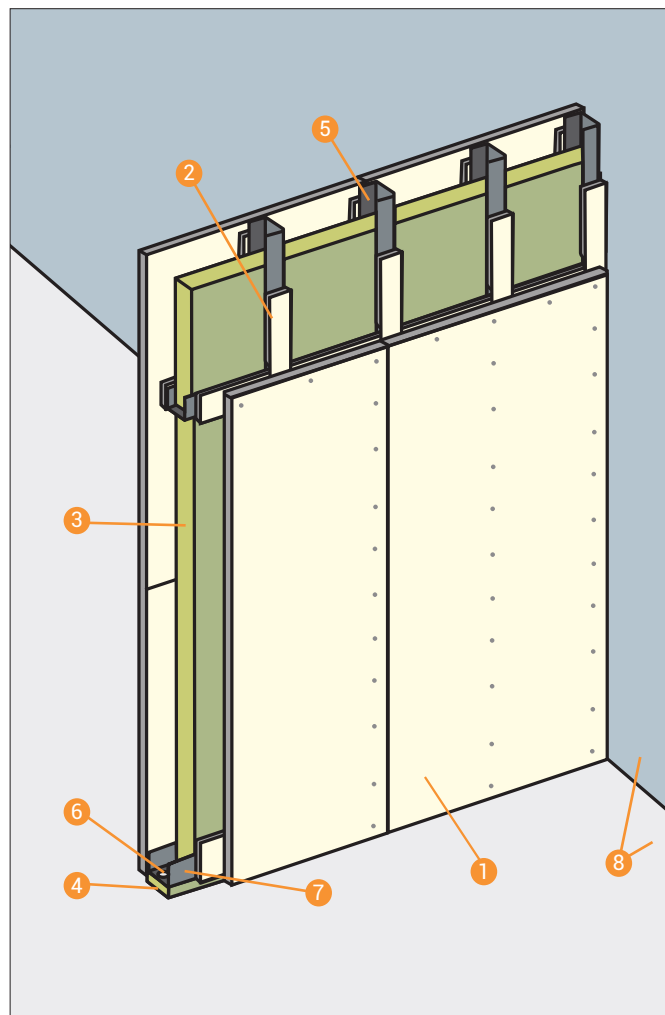

## Steel Frame

### TECHNICAL DATA - OPTION 1 (Using 9mm board)

120 minutes fire rating, integrity and insulation in accordance with BS 476: Part 22: 1987.

Nominal thickness of partition:	96mm
Partition height:	6.0m (see table below for heights over 6m)
Estimated sound insulation:	Rw 48dB

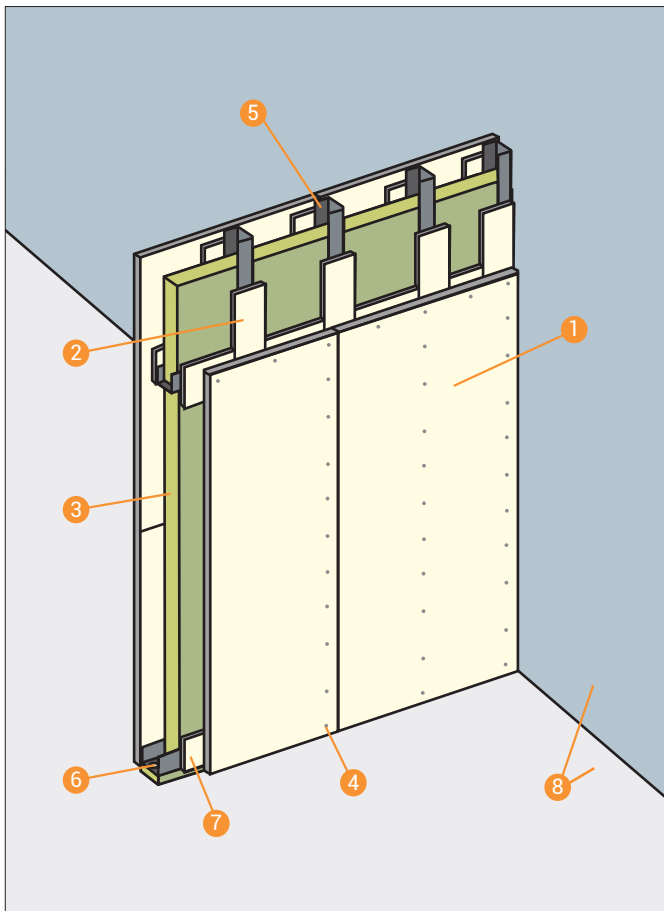

- 1 FireKem FP-900® board 9mm thick each side, butt jointed.
- 2 FireKem FP-900® cover strips 100mm x 9mm thick fixed to both vertical and horizontal studs each side, with self-tapping screws at nominal 400mm centres.
- 3 Rock wool, minimum 70mm thick x 100kg/m<sup>3</sup>, applied in 2 layers with all joints staggered between layers by minimum 150mm.
- 4 M4 x 32mm self-tapping screws at nominal 300mm centres
- 5 Steel studding 60mm x 49mm x 32/34mm, fixed at 600mm centres.
- 6 M6 steel anchor bolt at nominal 500mm centres .
- 7 Steel channel ceiling and floor 61mm x 40mm x 0.5mm.
- 8 Concrete wall or floor slab.

Size of C-Studs (mm)				Max. Height with Studs Centre of 600mm (m)
Web	Flange	Llp	Gauge	
60	32/34	6.5	0.5	6.00
70	32/34	6.5	0.5	6.75
70	32/34	6.5	0.7	7.45
73	32/34	6.5	0.5	6.90
92	32/34	6.5	0.5	8.25
146	32/34	6.5	0.5	11.95
146	32/34	6.5	0.7	12.00
58.8	47/49	6.0	0.6	6.75
73.8	47/49	6.0	0.6	8.00
73.8	47/49	6.0	0.7	8.35
73.8	47/49	6.0	1.0	9.35
98.8	47/49	6.0	0.6	9.90
98.8	47/49	6.0	0.7	10.40
98.8	47/49	6.0	1.0	11.60
123.8	47/49	6.0	0.6	11.75
148.8	47/49	6.0	0.6	12.00

Table 1. The max. partition height for various sizes of the steel studs

Height (m)	Min. Depth of Top Channel (mm)	Clearance at top Track (mm)
3	40	15
4	40	20
5	50	24
6	50	28
8	60	35
10	70	42
12	75	50

Table 2. The min. depth of the top steel channel and the min. expansion allowance for the studs at different partition heights.

## Steel Frame

### TECHNICAL DATA- OPTION 2 (Using 12mm board)

120 minutes fire rating, integrity and insulation in accordance with BS 476: Part 22: 1987.

Nominal thickness of partition:	84mm
Partition height:	6.0m (see table below for heights over 6m)
Estimated sound insulation:	Rw 48dB

- 1 FireKem FP-900® board 12mm thick each side, butt jointed.
- 2 FireKem FP-900® coverstrips 100mm wide x 12mm thick at horizontal board joints and fixed with M4 Self-tapping screws at nominal 200mm centres on both sides of the joint.
- 3 Rock wool, minimum 70mm thick x 100kg/m<sup>3</sup>, applied in 2 layers with all joints staggered between layers by minimum 150mm.
- 4 Steel stud minimum 60mm x 32/34mm x 0.5mm at nominal 600mm centres.
- 5 Steel channel ceiling and floor 61mm x 40mm x 0.5mm.
- 6 M6 Steel anchor bolts 500 centres.
- 7 M4 Self-tapping screws at nominal 300mm centres.
- 8 Concrete wall or floor slab.

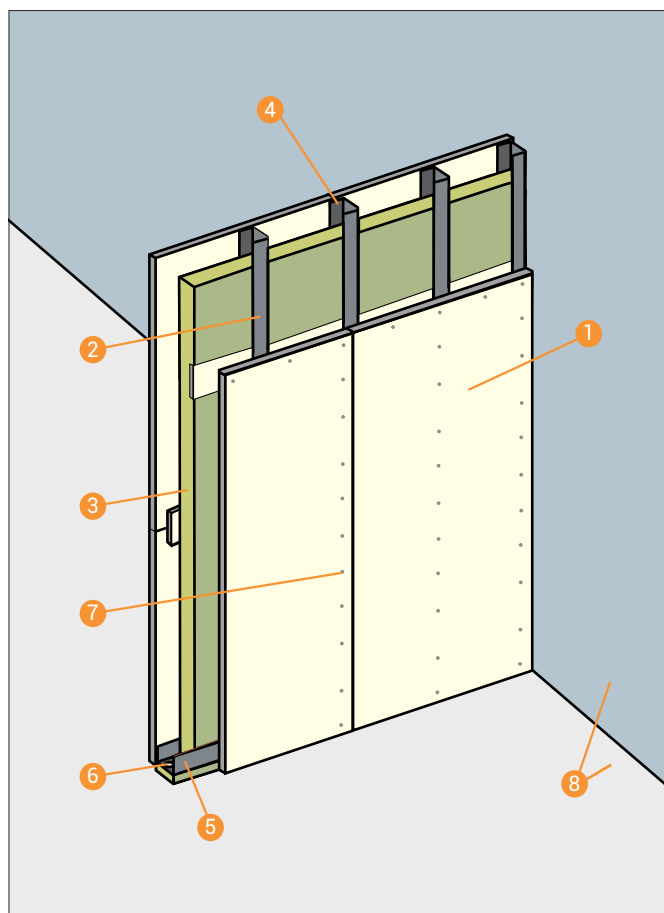

Height (m)	Min. Depth of Top Channel (mm)	Clearance at top Track (mm)
3	40	15
4	40	20
5	50	24
6	50	28
8	60	35
10	70	42
12	75	50

Table 1. The min. depth of the top steel channel and the min. expansion allowance for the studs at different partition heights.

Size of C-Studs (mm)				Max. Height with Studs Centre of 600mm (m)
Web	Flange	Llp	Gauge	
60	32/34	6.5	0.5	5.65
70	32/34	6.5	0.5	6.35
70	32/34	6.5	0.7	7.10
73	32/34	6.5	0.5	6.55
92	32/34	6.5	0.5	7.80
146	32/34	6.5	0.5	11.30
146	32/34	6.5	0.7	12.00
58.8	47/49	6.0	0.6	6.35
73.8	47/49	6.0	0.6	7.55
73.8	47/49	6.0	0.7	8.00
73.8	47/49	6.0	1.0	8.90
98.8	47/49	6.0	0.6	9.45
98.8	47/49	6.0	0.7	9.90
98.8	47/49	6.0	1.0	11.05
123.8	47/49	6.0	0.6	11.25
148.8	47/49	6.0	0.6	12.00

Table 2. The max. partition height for various sizes of the steel studs

## Steel Frame

### TECHNICAL DATA - OPTION 3 (Using 15mm board)

120 minutes fire rating, integrity and insulation in accordance with BS 476: Part 22: 1987.

Nominal thickness of partition:	90mm
Partition height:	6.0m (see table below for heights over 6m)
Estimated sound insulation:	Rw 48dB

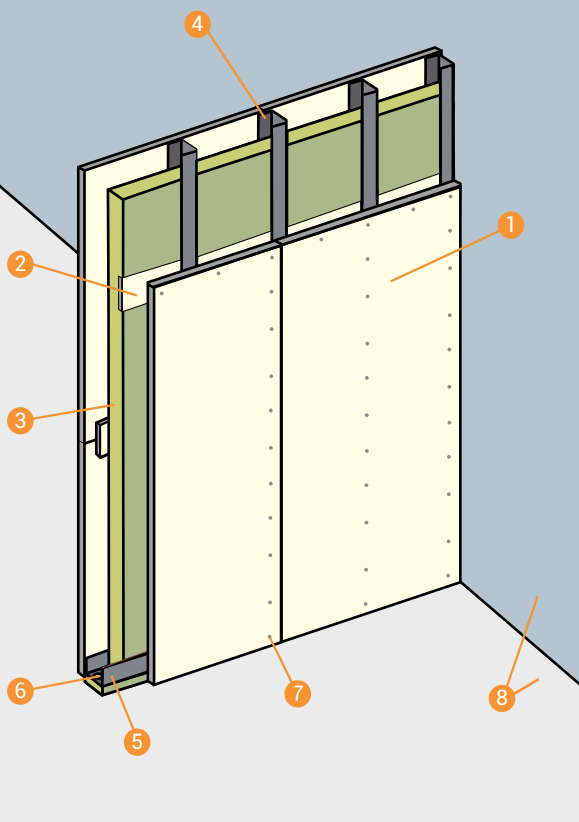

- 1 FireKem FP-900® board 15mm thick each side, butt jointed.
- 2 FireKem FP-900® coverstrips 100mm X 15mm thick at horizontal board joints and fixed with M4 Self-tapping screws at nominal 200mm centres on both sides of the joint
- 3 Rock wool, minimum 70mm thick x 100kg/m<sup>3</sup>, applied in 2 layers with all joints staggered between layers by minimum 150mm.
- 4 Steel stud minimum 60mm x 32/34mm x 0.5mm at nominal 600mm centres.
- 5 Steel channel ceiling and floor 61mm x 40mm x 0.5mm.
- 6 M6 Steel anchor bolts 500 centres.
- 7 M4 Self-tapping screws at nominal 300mm centres.
- 8 Concrete wall or floor slab.

Size of C-Studs (mm)				Max. Height with Studs Centre of 600mm (m)
Web	Flange	Lip	Gauge	
60	32/34	6.5	0.5	5.50
70	32/34	6.5	0.5	6.15
70	32/34	6.5	0.7	6.85
73	32/34	6.5	0.5	6.30
92	32/34	6.5	0.5	7.55
146	32/34	6.5	0.5	11.00
146	32/34	6.5	0.7	12.00
58.8	47/49	6.0	0.6	6.25
73.8	47/49	6.0	0.6	7.30
73.8	47/49	6.0	0.7	7.65
73.8	47/49	6.0	1.0	8.65
98.8	47/49	6.0	0.6	9.10
98.8	47/49	6.0	0.7	9.55
98.8	47/49	6.0	1.0	10.70
123.8	47/49	6.0	0.6	10.80
148.8	47/49	6.0	0.6	12.00

Table 1. The max. partition height for various sizes of the steel studs

Height (m)	Min. Depth of Top Channel (mm)	Clearance at top Track (mm)
3	40	15
4	40	20
5	50	24
6	50	28
8	60	35
10	70	42
12	75	50

Table 2. The Min. depth of the top steel channel and the min. expansion allowance for the studs at different partition heights.

## TECHNICAL DATA

120 minutes fire rating, integrity and insulation in accordance with BS 476: Part 22: 1987, for fire exposure from either face.

- 1 Perimeter channels 75mm x 40mm x 0.8mm are bedded on stone wool or intumescent sealant and fastened to the surrounding construction with M6 steel anchor bolts at 500mm nominal centres
- 2 Steel channels i-Studs 72mm x 32mm x 0.8mm, fixed back to back with m5 steel self-tapping screws at 300mm centres. The i-Studs are spaced at 600 maximum centres
- 3 2 no. FireKem FP-900® fillets 100mm wide x 12mm thick covering the steel studs and channels at the room face of the steel framework, fastened with m3.5mm steel self-tapping screws at 400mm nominal centres
- 4 FireKem FP-900® boards to shaft face, 12mm thick, tightly fitted between the studs and held in place with steel securing angles, 50mm x 32mm x 0.5mm, fixed to the steel stud wall with m3.5mm self-tapping screws at nominal 300 centres
- 5 FireKem FP-900® board 12mm thick on the room face screwed to the studs and perimeter channels, through the fillets with m3 5mm self-tapping screws at nominal 300mm centres. All screws are positioned nominal 12mm from the board edge and 40mm from the board corners. Vertical board joints coincide with the studs
- 6 Horizontal board joints are backed by FireKem FP-900® cover strips 100mm x 9mm thick, fastened using m3.5mm self-tapping screws at nominal 200mm centres on both sides of the joint
- 7 Rock mineral wool is fitted tightly between the studs, 100mm thick x 100Kg/m<sup>3</sup> in 2 layers of 50mm with staggered joints. For maximum partition height see table.

**EI60 shaftwall for fire exposure from either face, also available. Please contact Kemwell PFP for details.**

### PARTION HEIGHT

As the height of the partition increases, the minimum requirements for the steel framework also must increase. The table shows the maximum partition height for various sizes of the steel studs. The minimum depth of the top steel channel and the minimum expansion allowance for the studs at different partition heights (see chart below). The allowance for expansion may be provided at stud joints and/or by the studs sliding up into the top channel. Any joint in the stud that incorporates an expansion allowance must not decrease the strength of the stud.

### DEFLECTION HEAD

For heights above 5m a deflection head arrangement must be fitted to the top of the partition to allow for expansion of the steel studs. On the shaft face the FireKem FP-900 facing boards are stopped short of the web for the top channel by a distance of at least the required expansion allowance. On the room face the FP-900 facing boards and fillets are stopped short of the allowance. An additional FP-900 cover fillet 9mm thick, is fitted to the top channel and a FP-900 cover strip minimum 9mm thick screwed to the top channel through fillets. The cover panel overlaps the facing boards by at least 50mm. It must be ensured that the screw fixing for the boards do not restrict the expansion allowance.

### INSULATION

When the web dimension of the studs is increased, thus increasing the depth of the cavity in the partition, then the thickness of the stone wool must be increased to fill the cavity. Alternative thicknesses and densities of stone wool insulation may be fitted provided that the weight per square metre is at least that specified and that the percentage of binder content by weight does not exceed that of the insulation fitted in the tested constructions.

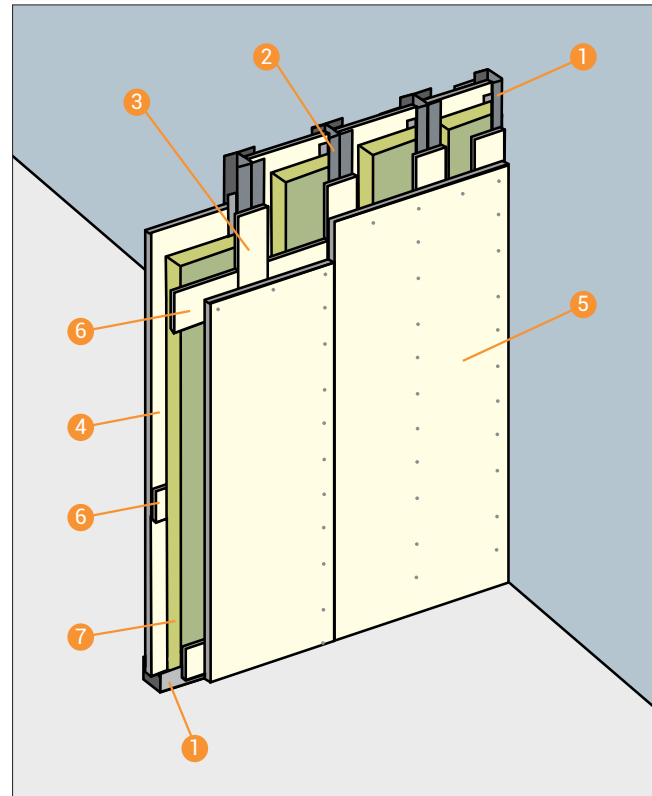

Height (m)	Min. Depth of	Minimum expansion
3	40	15
4	40	20
5	50	24
6	50	28
8	60	35

Size of channels forming max. Height (m) with back to back studs (mm) with Studs Centres of:

Web	Flange	Gauge	610mm
75	32	0.8	5.0
75	45	0.8	5.1
75	50	0.8	5.2
94	45	1.0	6.8
94	45	1.2	7.1
102	45	1.0	7.3
102	45	1.2	7.7
127	50	1.5	8.0

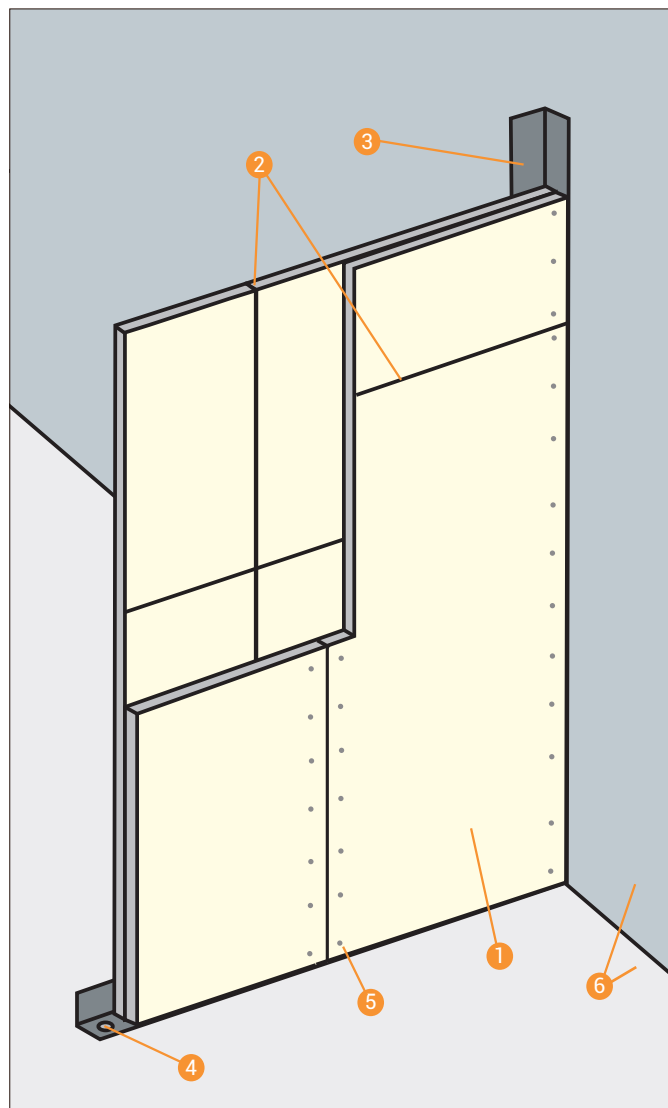

## FireKem FP-900® Solid Partition

### TECHNICAL DATA

60 minutes fire rating, integrity and insulation in accordance with the criteria of BS 476: Part 22: 1987.

Nominal thickness of partition:	32mm
Maximum partition height:	6.0m
Estimated sound insulation:	Rw 32dB

- 1 FireKem FP-900® boards 20mm + 12mm.
- 2 All joints staggered between layers.  
The first layer 20mm, fixed to perimeter angle using M4 screws at 300mm centres.  
  
Second layer 12mm, fixed to first layer using M4 x 45mm screws at 300mm centres around the perimeter and down the centre of each panel. Take care not to over tighten screws.
- 3 Steel angle frame, minimum 50 x 30 x 1.5mm bedded on intumescent sealant.
- 4 M6 steel anchor bolt at nominal 500mm centres.
- 5 M4 self-tapping screws.
- 6 Concrete wall or floor slab.

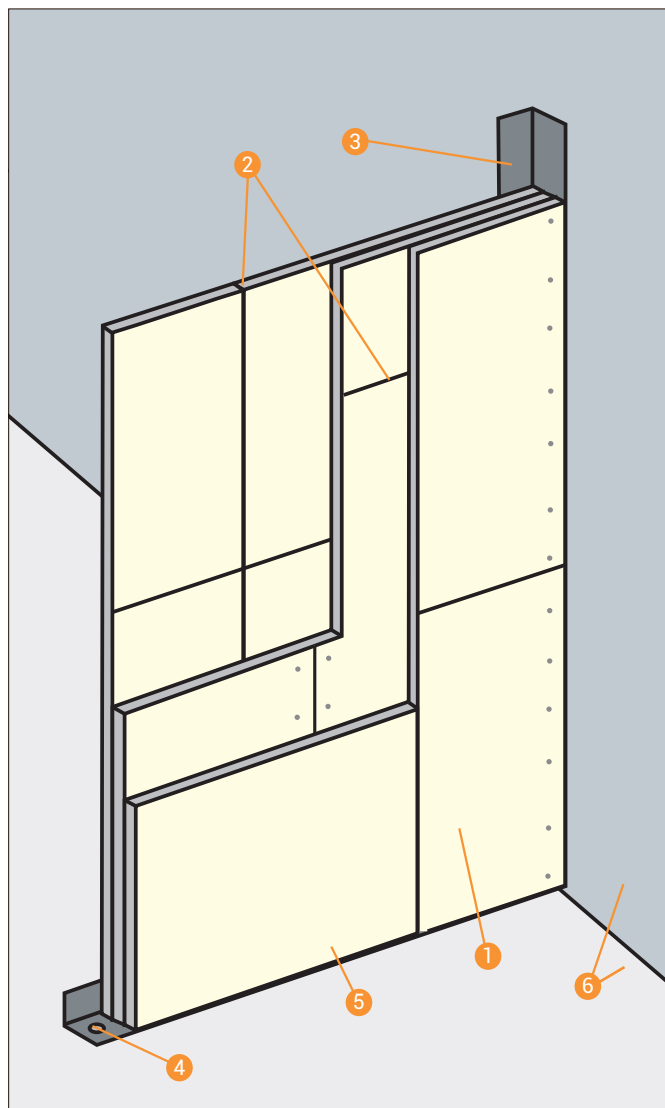

## FireKem FP-900® Solid Partitions

### TECHNICAL DATA

120 minutes fire rating, integrity and insulation in accordance with the criteria of BS 476: Part 22: 1987.

Nominal thickness of partition:	52mm
Maximum partition height:	6.0m
Estimated sound insulation:	Rw 38dB

- 1 FireKem FP-900® boards, 20mm + 20mm + 12mm.
- 2 All joints staggered between layers.  
The first layer 20mm, fixed to perimeter angle using M4 screws at 300mm centres. Second layer 20mm, fixed to first layer using M4 x 30mm screws at 300mm centres around the perimeter and on both sides of each joint. Third layer 12mm, fixed to first two layers using M4 x 45mm screws at 300mm centres around the perimeter and down the centre of each panel. Take care not to over tighten screws.
- 3 Steel angle frame, minimum 50 x 50 x 2mm bedded on intumescent sealant.
- 4 M6 steel anchor bolt at nominal 500mm centres.
- 5 M4 self-tapping screws.
- 6 Concrete wall or floor slab.

Solid Partitions EI 30 to EI 240 Integrity and Insulation in both directions

Solid Partition fire rating Integrity and Insulation	Minimum total thickness of FireKem-FP-900 Board
30 minutes	28mm
60 minutes	32mm
90 minutes	42mm
120 minutes	52mm
240 minutes	100mm

The Solid Partition can be constructed with multiple layers of 9mm, 12mm and 15mm to the required minimum thickness.

The above tested details are as per Warringtonfire WF Report 433366/R Issue 2 dated 19th October 2020

# Fire Protection to Wind Posts up to 120 minutes

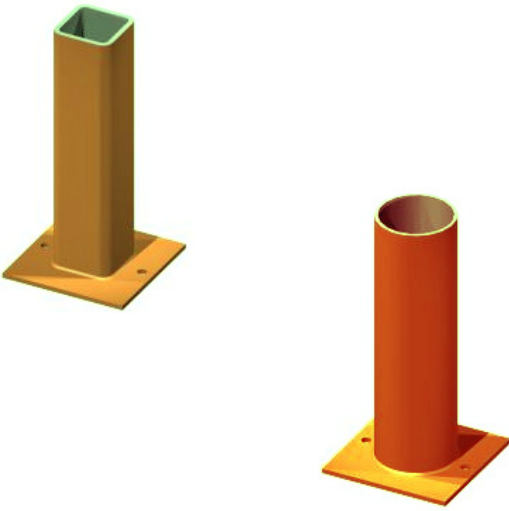
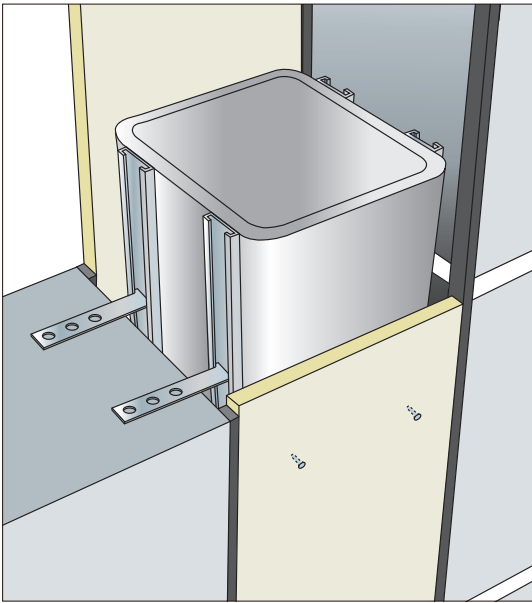

RHS and SHS Steel sections are generally used for wind posts. In situations where the walls are also required to provide fire resistance between two compartments, the fire protection applied to the wind post must also maintain the fire separation across the wall construction at that point.

The wind post will normally require fire protection for the same period as the supported wall, fire will normally be considered to occur from either face.

SHS Windposts are available in a wide range of sizes, lengths and finishes to suit each application and come complete with necessary fixings. Ties would either be shot fired or tech screwed to the section.

**FIXINGS**

FireKem FP-900 panels can be installed recessed or flush with the block wall, FireKem FP-900 can be fastened directly to both faces of the steel section, using either No. 8 steel self-tapping screws at nominal 300mm centres or 3.6mm (3.7mm) steel shot fired nails at 300mm nominal centres. Self-drilling, self-tapping screws may also be used.

Where horizontal joints occur, a nominal 3mm gap must also be left between FireKem FP-900 panels and fully filled with intumescent sealant.

Alternatively, FireKem FP-900 panels may be fastened to the face of the block wall through 75mm x 9mm thick FireKem FP-900 fillets either side of the hollow section into non-combustable plugs. The fixing should penetrate the block work by a minimum of 30mm and be a minimum of 50mm from the edge of the block work.

With this cladding, an internal FireKem FP-900 cover strip (minimum 6mm thick) must be fitted behind any horizontal FireKem FP-900 joint. The cover strip must leave a minimum 6mm clearance to the steel post.

The screw or nails must penetrate at least 10mm beyond the interface of FireKem FP-900 and the steel, and are staggered approximately 30mm from alternate edges of the steel post. At any horizontal FireKem FP-900 joint, there must be fixings 20mm above and below the joint. The screws and nails may be fitted with or without steel washers.

A nominal 3mm gap must be left between the edge of the FireKem FP-900 panel and the block work. This must be fully filled with intumescent sealant.

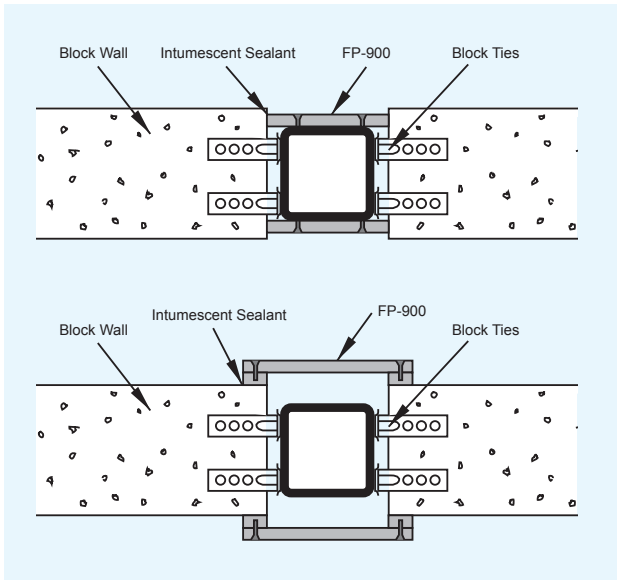



# Fire Protection to Wind Posts up to 120 minutes

## Two sided Wind Post Encasement

Size D x D	Wall Mass	Area of Section	Thickness	3 sides	4 sides
mm	mm	kg/m	cm2	m-1	m-1
80 x 80 mm	3.0	7.18	9.14	265	350
	3.2	7.63	9.72	250	330
	3.6	8.53	10.9	220	295
	4.0	9.41	12.0	200	270
	5.0	11.6	14.7	165	220
90 x 90mm	3.6	9.66	12.3	220	295
	4.0	10.7	13.6	200	265
	5.0	13.1	16.7	160	215
	6.3	16.2	20.7	130	175
	8.0	20.1	25.6	105	140
100 x 100mm	3.6	10.8	13.7	220	295
	4.0	11.9	15.2	200	265
	5.0	14.7	18.7	160	215
	6.3	18.2	23.2	130	175
	8.0	22.6	28.8	105	140
120 x 120mm	4.0	14.4	18.4	195	260
	5.0	17.8	22.7	160	215
	6.3	22.2	28.2	130	170
	8.0	27.6	35.2	105	140
	10.0	33.7	42.9	85	115
140 x 140mm	5.0	21.0	26.7	160	210
	6.3	26.1	33.3	130	170
	8.0	32.6	41.6	100	135
	10.0	40.0	50.9	85	110
	12.5	48.7	62.1	70	90

Size D x D	Wall Mass	Area of Section	Thickness	3 sides	4 sides
mm	mm	kg/m	cm <sup>2</sup>	m-1	m-1
Square Hollow Sections Section factor					
150 x 150mm	5.0	22.6	28.7	160	210
	6.3	28.1	35.8	125	170
	8.0	35.1	44.8	100	135
	10.0	43.1	54.9	85	110
	12.5	52.7	67.1	70	90
160 x 160mm	5.0	24.1	30.7	160	210
	6.3	30.1	38.3	125	170
	8.0	37.6	48.0	100	135
	10.0	46.3	58.9	85	110
	12.5	56.6	72.1	70	90
180 x 180mm	5.0	27.3	34.7	155	210
	6.3	34.0	43.3	125	170
	8.0	42.7	54.4	100	135
	10.0	52.5	66.9	80	110
	12.5	64.4	82.1	65	90
	14.2	72.2	92.0	60	80
	16.0	80.2	102	55	70

Note: Wind posts that project beyond the face of the block wall, contact the Kemwell PFP Technical Department.

## Two sided Wind Post Encasement

Steel Section Thickness	5mm						
	5mm	6.3mm	8mm	10mm	12.5mm	16mm	
Face width of steel Wind Posts (viewed from the front)	50mm	9mm	9mm	9mm	9mm	9mm	
	60mm	12mm	9mm	9mm	9mm	9mm	
	70mm	12mm	9mm	9mm	9mm	9mm	
	80mm	12mm	12mm	9mm	9mm	9mm	
	90mm	12mm	12mm	9mm	9mm	9mm	
	100mm	12mm	12mm	12mm	9mm	9mm	
	120mm	15mm	12mm	12mm	12mm	9mm	
	140mm	15mm	15mm	12mm	12mm	9mm	
	150mm	15mm	15mm	12mm	12mm	12mm	
	160mm	15mm	15mm	12mm	12mm	12mm	
	180mm	20mm	15mm	15mm	12mm	12mm	
	200mm	20mm	15mm	15mm	12mm	12mm	
250mm	20mm	20mm	15mm	15mm	15mm		

Note: Wind posts that project beyond the face of the block wall, contact the Kemwell PFP Technical Department

## BOARD SIZES

The available sizes are: 9mm, 12mm, 15mm, 20mm and 25mm available to order.

### Boards manufactured in accordance with:

ISO 9001:2008 Standard Quality Management Systems

ISO 14001:2004 Environmental Management Systems



### MEASUREMENTS

Thickness	9 / 12 / 14 / 18 / 20 / 25mm
Width	1200mm
Length	2400mm

### MANUFACTURING TOLERANCES

Length Tolerance	+/- 5mm
Width Tolerance	+/- 5mm
Thickness Tolerance	+/- 0.3mm
Diagonal Tolerance	+/- 5mm



# TECHNICAL PROPERTIES

## PHYSICAL PROPERTIES

	Standard	Additional Information
Density		900kg/m <sup>3</sup> (+/-10%)
Nominal Weight		8.9kg/m <sup>2</sup> – 9mm
		11.9kg/m <sup>2</sup> – 12mm
		14.8kg/m <sup>2</sup> – 15mm
Surface Alkalinity		pH 7-10
Flexural Strength		6.0 MPa (along grain)
Flexural Strength		9.5 MPa (across grain)
Moisture Movement (ambient to saturated)		0.05%
Dimensional Changes in Length due to Relative Humidity	BS EN 318	+0.01% @20°C, RH 30%~85%
		- 0.02% @20°C, RH 85%~30%
Moisture Content		Ex works - 15%
		In situ - 6%
Thermal Conductivity	EN 12264	0.17 W/mK
Linear Thermal Expansion	BS EN ISO 10515-8	-3.06 x 1E-6/°C

## FIRE PERFORMANCE

	Standard	Additional Information
Fire Rated Systems	BS 476: Part 20-24	Up to 240 minutes
	BS EN1363-1 & 2	
Non-combustible Test	BS 476: Part 4 BS EN ISO 1182	Pass
Heat of Combustion	BS EN ISO 1716	Pass
Reaction to Fire	EN 13501-1:2007	Euro Class A1
Surface Spread of Flame	BS 476: Part 7	Class 1
Fire Propagation Test	BS 476: Part 6	Class 0
Test for Ignitability	BS 476: Part 5	Class P
Minimum Bending Radius		Along grain
		7200mm for 9mm
		9800mm for 12mm

## ACOUSTIC PERFORMANCE

	Standard	Additional Information		
Acoustic Reduction (over range 100-3150 Hz)	AS 1276.1	Thickness	Rw, dB	STC
	AS 1191	9mm	26	26
	ASTM E90	99mm	46	46
	ASTM E413	Steel Stud Partition		
	BS EN ISO 140-3	105mm	49	49
	BS EN ISO 717-1	Steel Stud Partition		



**Kemwell PFP Limited**  
 Unit 61, The Avenue  
 Rubery  
 Birmingham  
 B45 9AL  
 United Kingdom

UK Office: +44 (0) 333 344 0699  
 Ireland Office: +353 (0) 1 565 3756

✉ info@kemwell-pfp.com  
 www.kemwell-pfp.com